



Chain Actuators 300N

WMU 836

Programmable 24VDC chain actuator for surface mounting for smoke and comfort ventilation.

For top hung, bottom hung, pivot and turning windows.

The actuator is approved according to EN 12101-2 with selected profiles - please contact WindowMaster for further information.

The electronics in this actuator can be programmed to suit specific requirements – i.e. pressure traction force, stroke, speed and sound level.

Actuator and chain brackets to be ordered separately.

Description

- to be used together with ±24V control units or control units with MotorLink™
- can be used together with espagnolette WMB
- external safety edge can be connected directly to the actuator (actuator version 'E')



- synchronisation of up to four window actuators – no need for an external synchronisation module
- genuine position feedback and three speeds when using control unit with MotorLink™
- soft close
- the electronics in this actuator can be programmed to suit specific requirements
- i.e. pressure- and traction force, stroke, speed/sound level
- built-in electronic load switch-off/end stop
- electronic actuator with micro controller
- the actuator has an integrated reverse function to ensure a prolonged life span of the window gaskets
- easy mounting

Technical Specifications

Part No.	08/WMU 836
Chain Opening	400, 600, 800 and 1000mm (programmable in 10mm increments)
Opening Speed	11mm/s
Pressure Force	Dependent on chain length
Tractive Force	300N
Nominal Voltage	24 VDC, max. 10% ripple
Current Consumption	1A
Size	34 x 47mm (H x D) length (L) depending on chain stroke – see table below
Colour	Anodized aluminium

Diagram

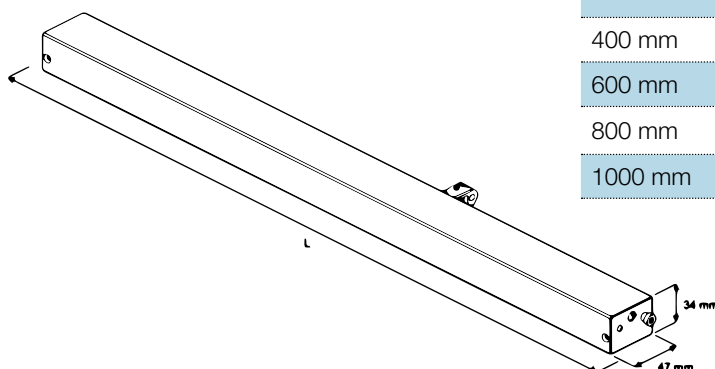

Chain Stroke	Compression Force (N)	Length (L)
400 mm	300N	568 mm
600 mm	300N	668 mm
800 mm	0*	768 mm
1000 mm	0*	868 mm